

六軸機械手臂應用:

6-axis robot application

Workpiece Payload: 7kg~12kg, 25~35kg, above 35kg (over 100kg).

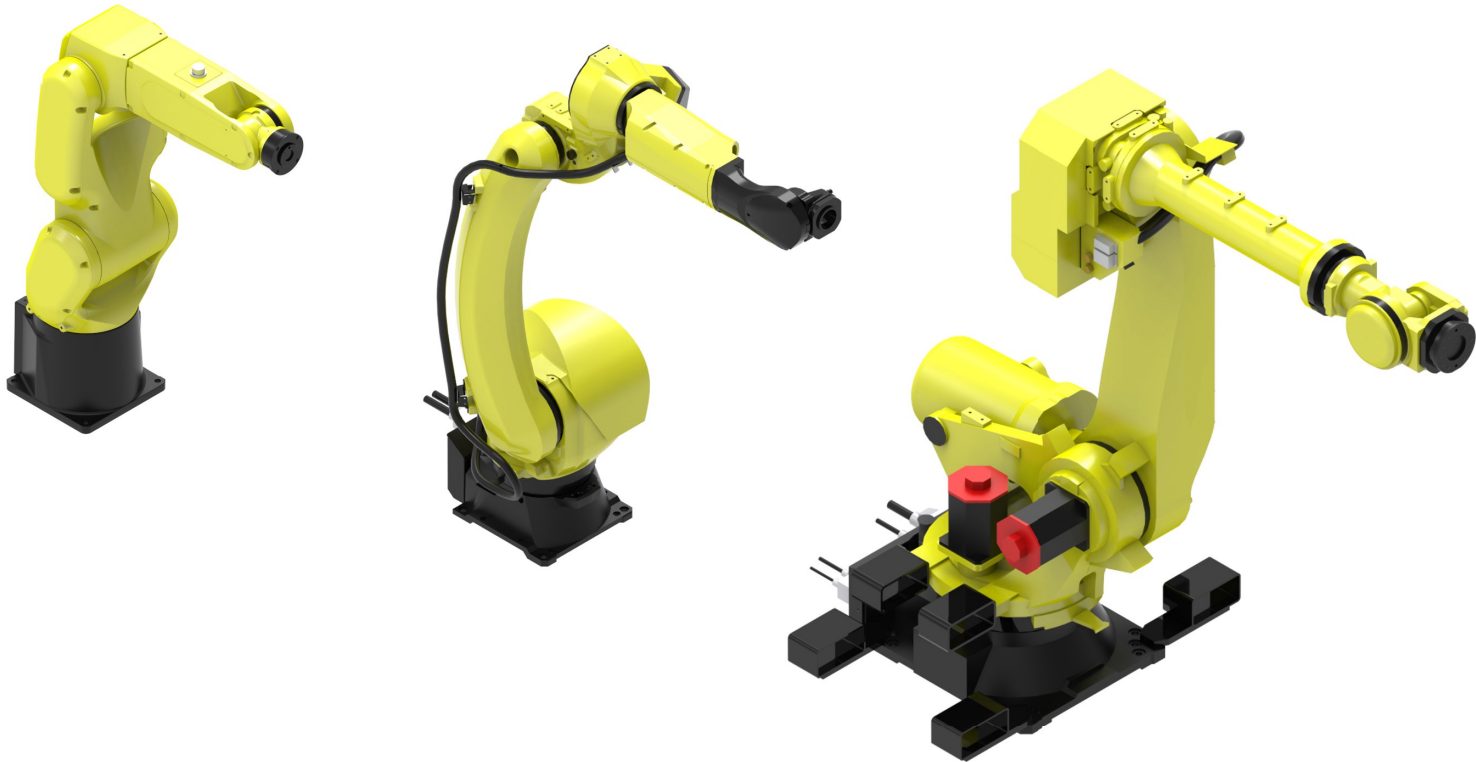

機械手臂專用夾爪組客製設計:
Customized gripper for robot.

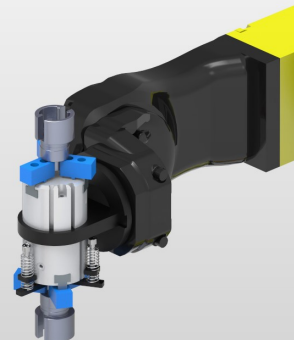
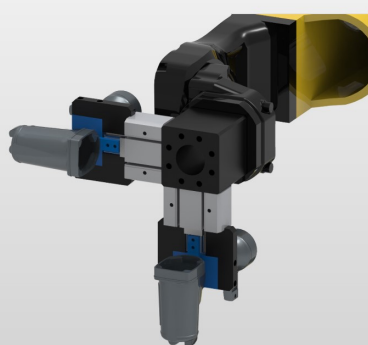
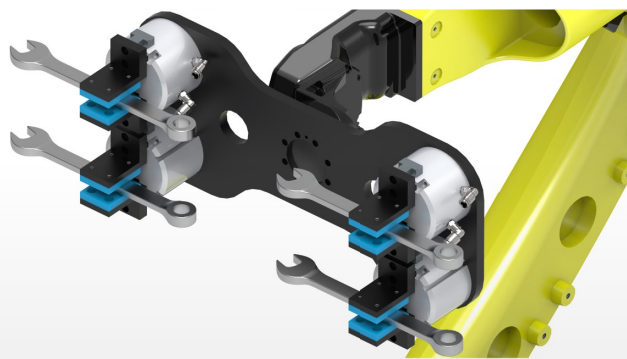
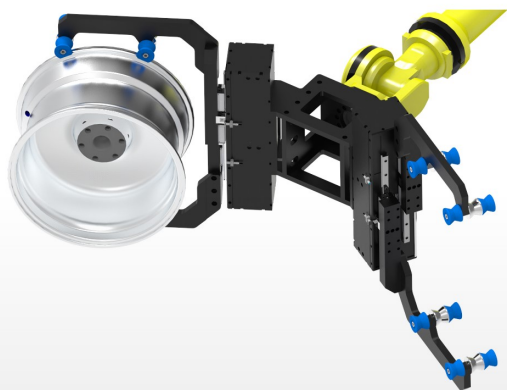

特色: Features:

- 工具機、供料機、自走軸等自動化設備
Automation: machine, work stocker, rail (7th-axis).
- 入料&取料無人化
Unmanned load and unload.
- 提升產線效率
Upgrade cycle time of production line.

台中市龍井區新庄街二段301號
TEL : 04-2652-9558
FAX : 04-2652-9557

www.autoplustek.com.tw



機械手臂自走軸-Robot On Rail

可搭載多種廠牌型號之機械手臂

Ex: 7kg、10kg、20kg、50kg、165kg...或更大負重能力之機械手臂。

Robot rail (7th-axis) combines with many types of robot.

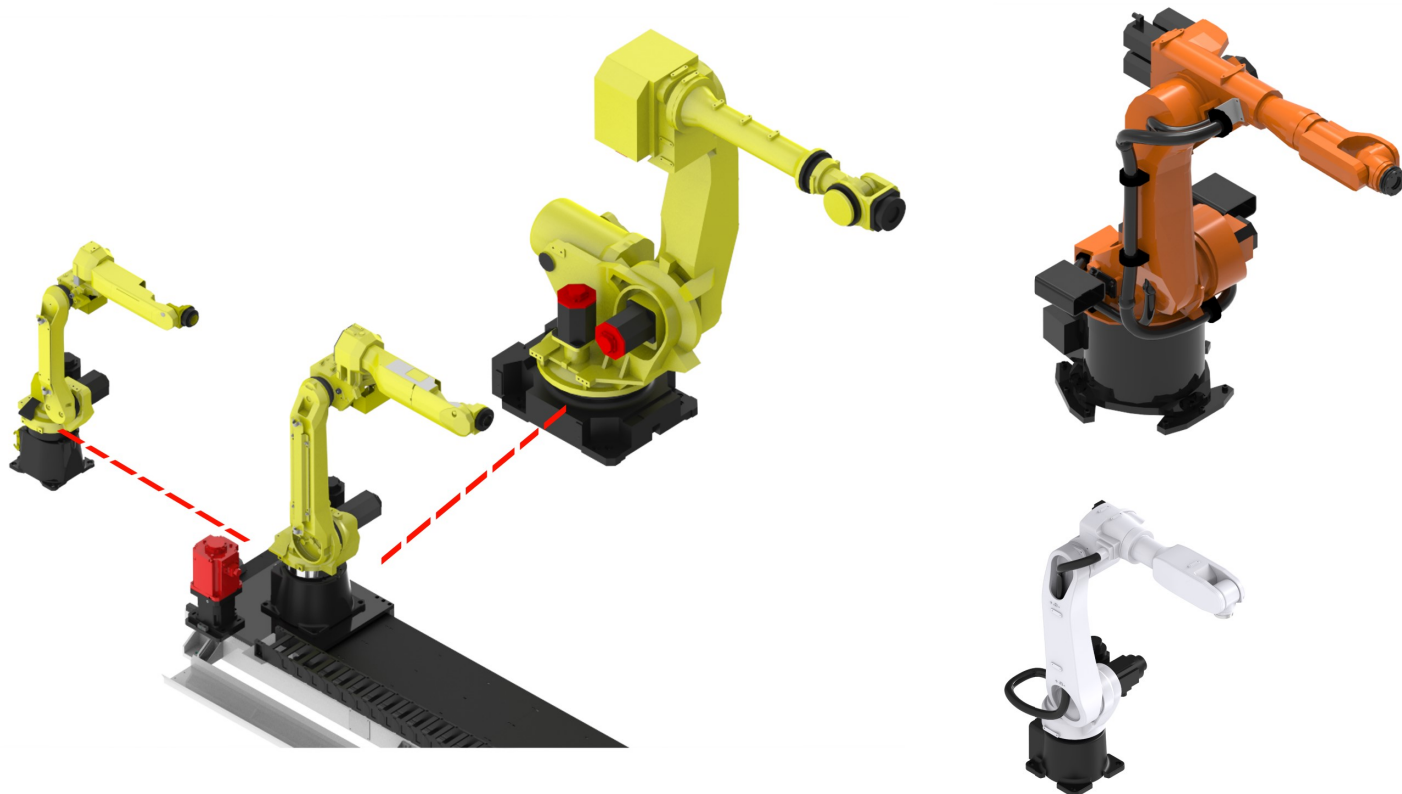

運作方向
Direction

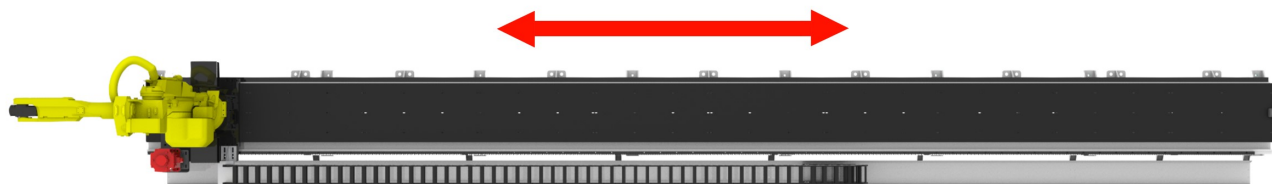

機械手臂用自走軸-Robot Rail

項目 Item	規格 Specification
軌道長度 Length	6M(標準)
軌道寬度 Width	依機械手臂型號 / By robot type
移動速度 Speed	60m/min (標準)

※以上數值均為參考規格，可依照客戶需求變更設計。

Above specification can be changed depended on customer requirement.

特色:

Features:

- 與關節機械手臂結合
Combining with axis robot.
- 更佳的作業機動性與靈活性
Greater mobility & flexibility.
- 節省時間、效率提升
Upgrade cycle time of product-line.



關節型機械手臂運用

運用範例:
Example:

飛輪產線自動化運用
Flywheel production line application

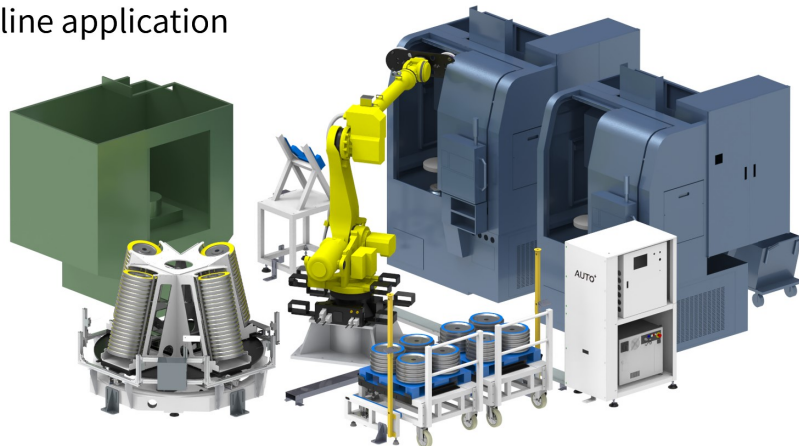

客製供料機
Work stocker

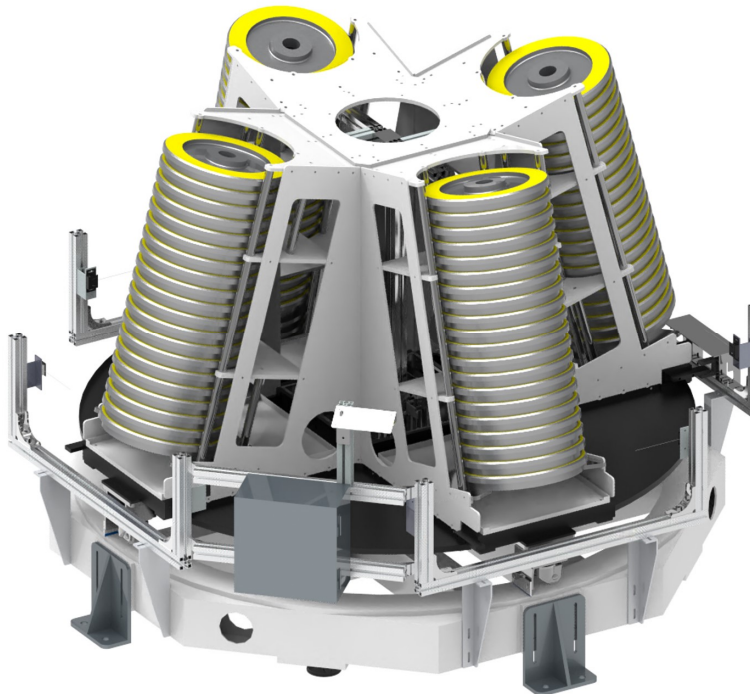

電磁夾爪組
Magnetic gripper (Customization)

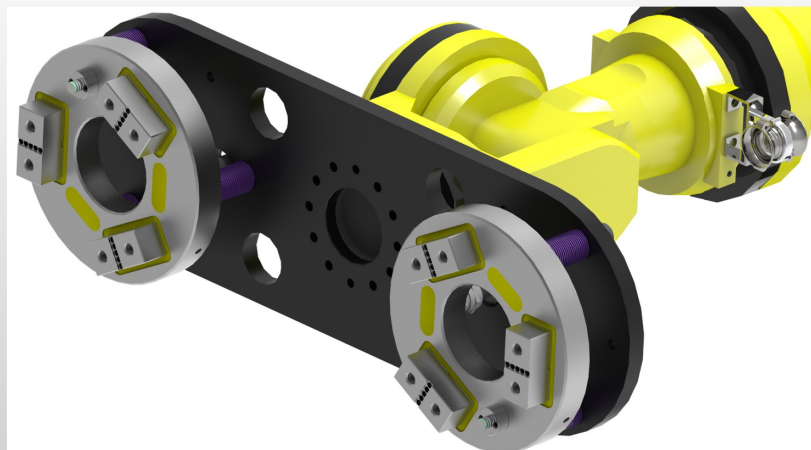

※以上圖片僅供參考，請以實際出貨設備/設計為準。
All Pictures shown are for illustration purpose only. Actual product/design may vary due to product enhancement.

關節型機械手臂運用

運用範例:
Example:

六軸機械手臂自走軸應用:
Industrial robot rail application

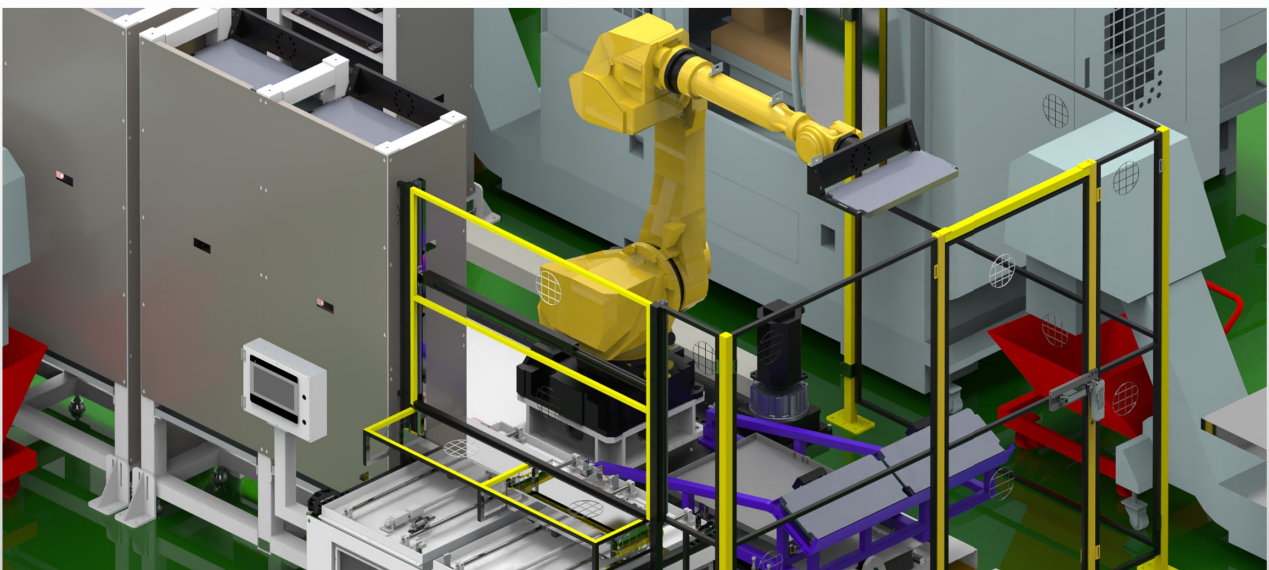
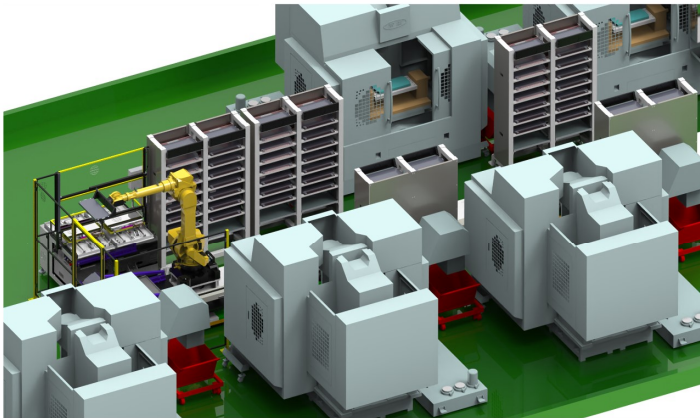
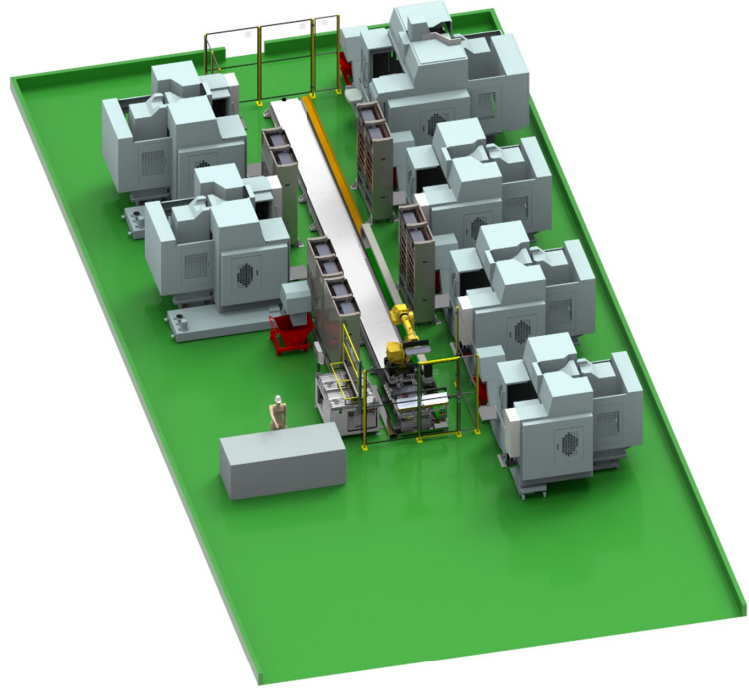
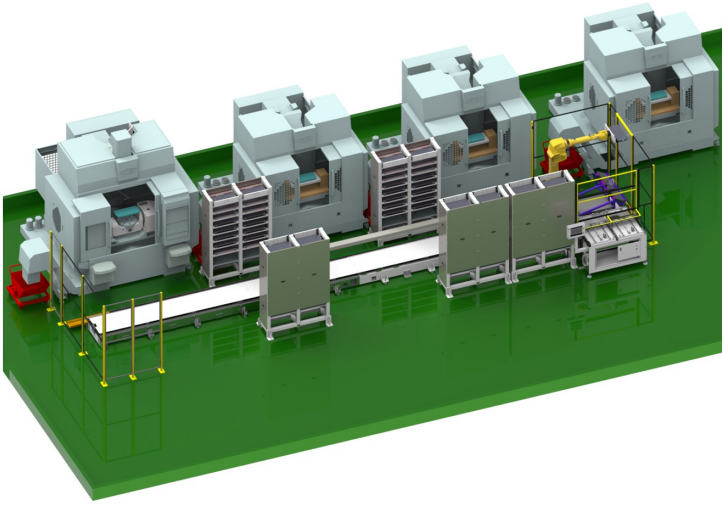

※以上圖片僅供參考，請以實際出貨設備/設計為準。

All Pictures shown are for illustration purpose only. Actual product/design may vary due to product enhancement.

關節型機械手臂運用

運用範例:
Example:

機械手臂導入接頭加工自動化
Automated connector production line

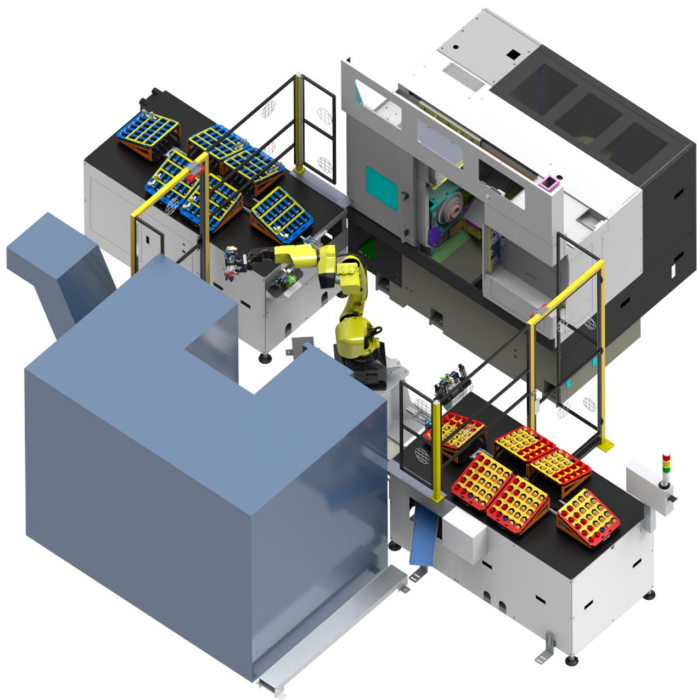

客製夾爪組
Customized gripper

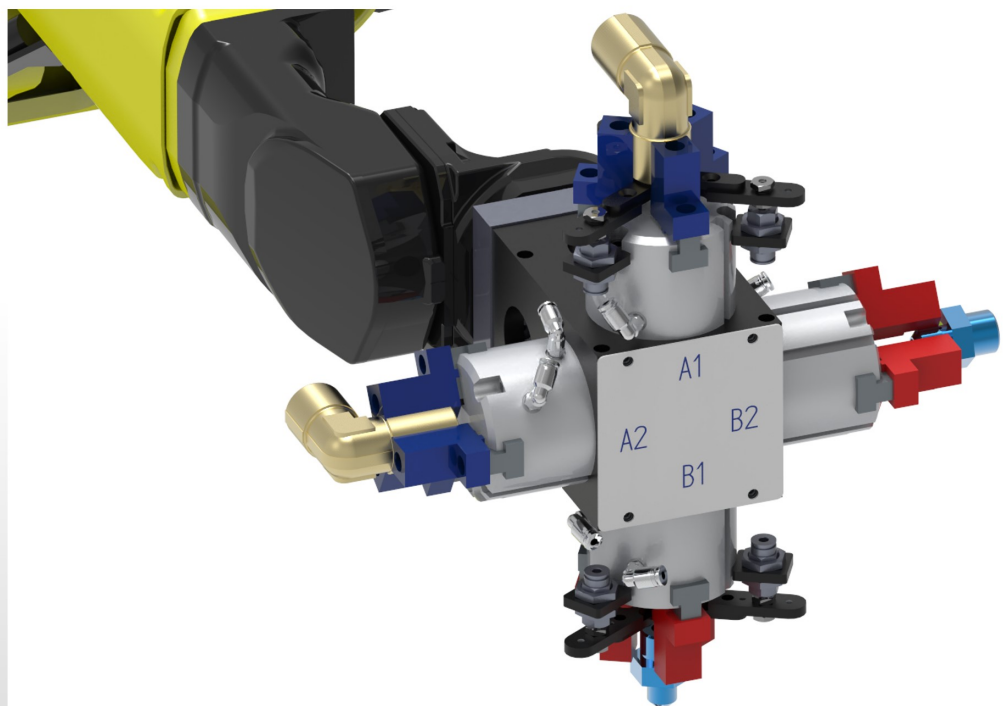

※以上圖片僅供參考，請以實際出貨設備/設計為準。

All Pictures shown are for illustration purpose only. Actual product/design may vary due to product enhancement.

關節型機械手臂運用

運用範例:
Example:

自行車花鼓零件加工自動化
Hub production line automation

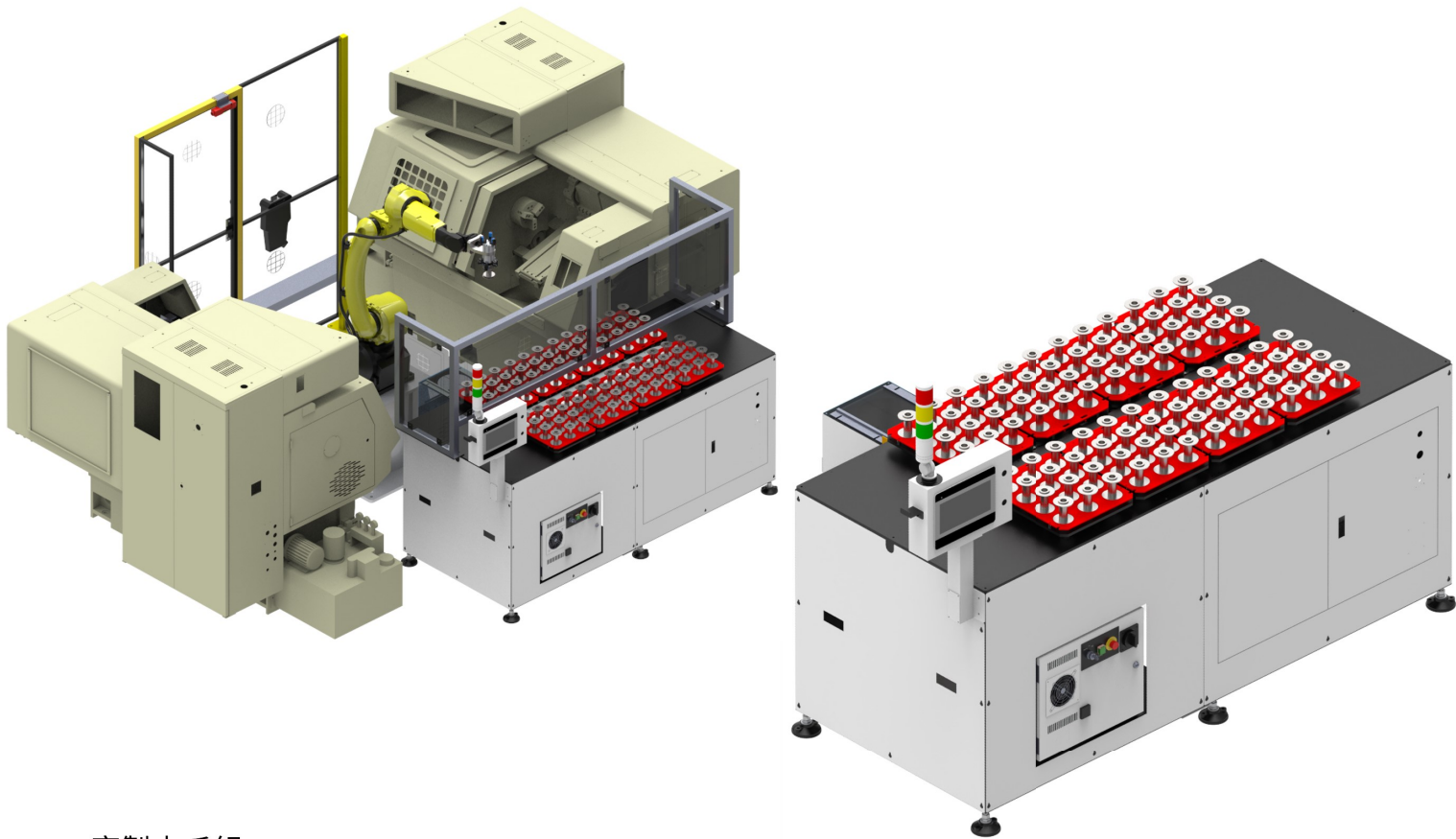

客製夾爪組
Customized gripper



※以上圖片僅供參考，請以實際出貨設備/設計為準。

All Pictures shown are for illustration purpose only. Actual product/design may vary due to product enhancement.

關節型機械手臂運用

運用範例:
Example:

機械手臂自走軸應用
Industrial robot rail application

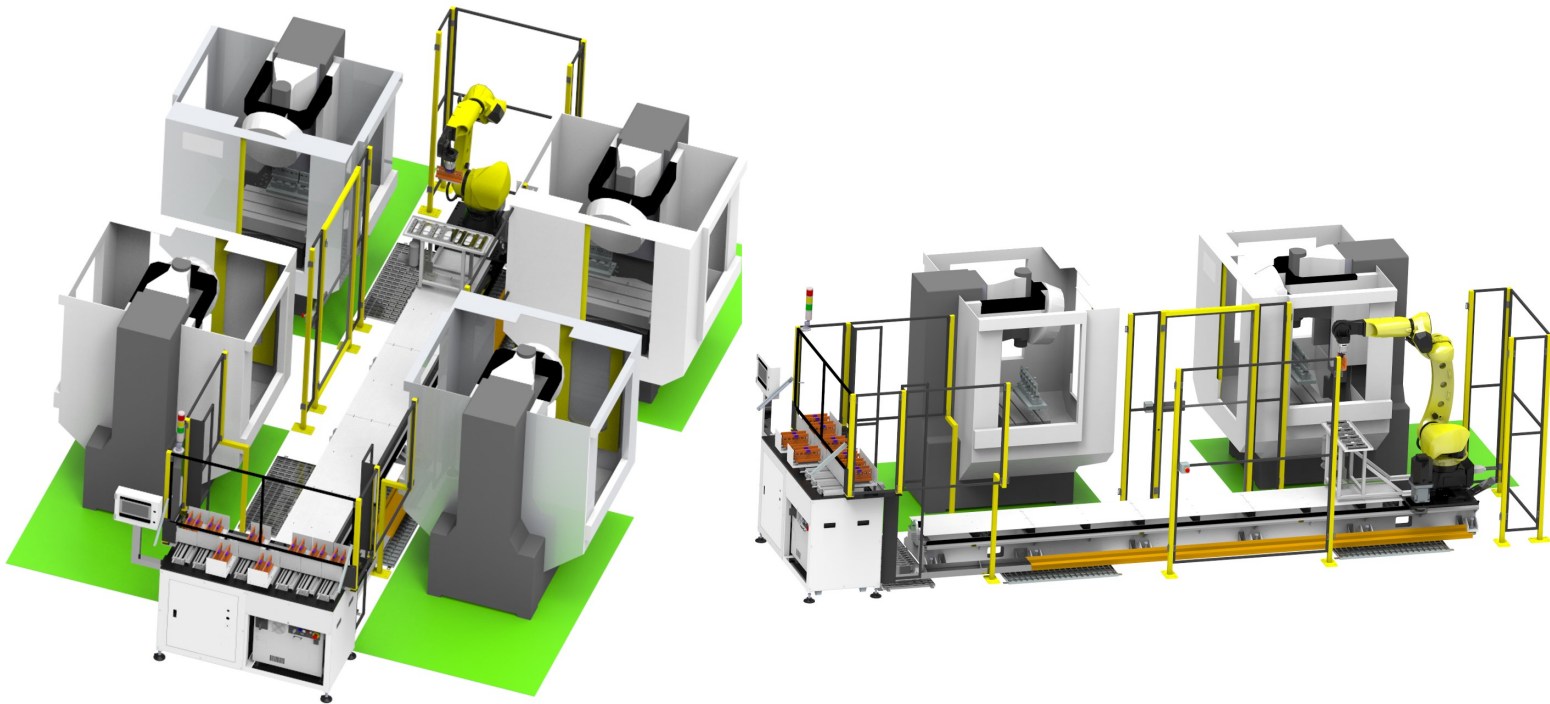

自走軸
Rail (7th axis for robot)

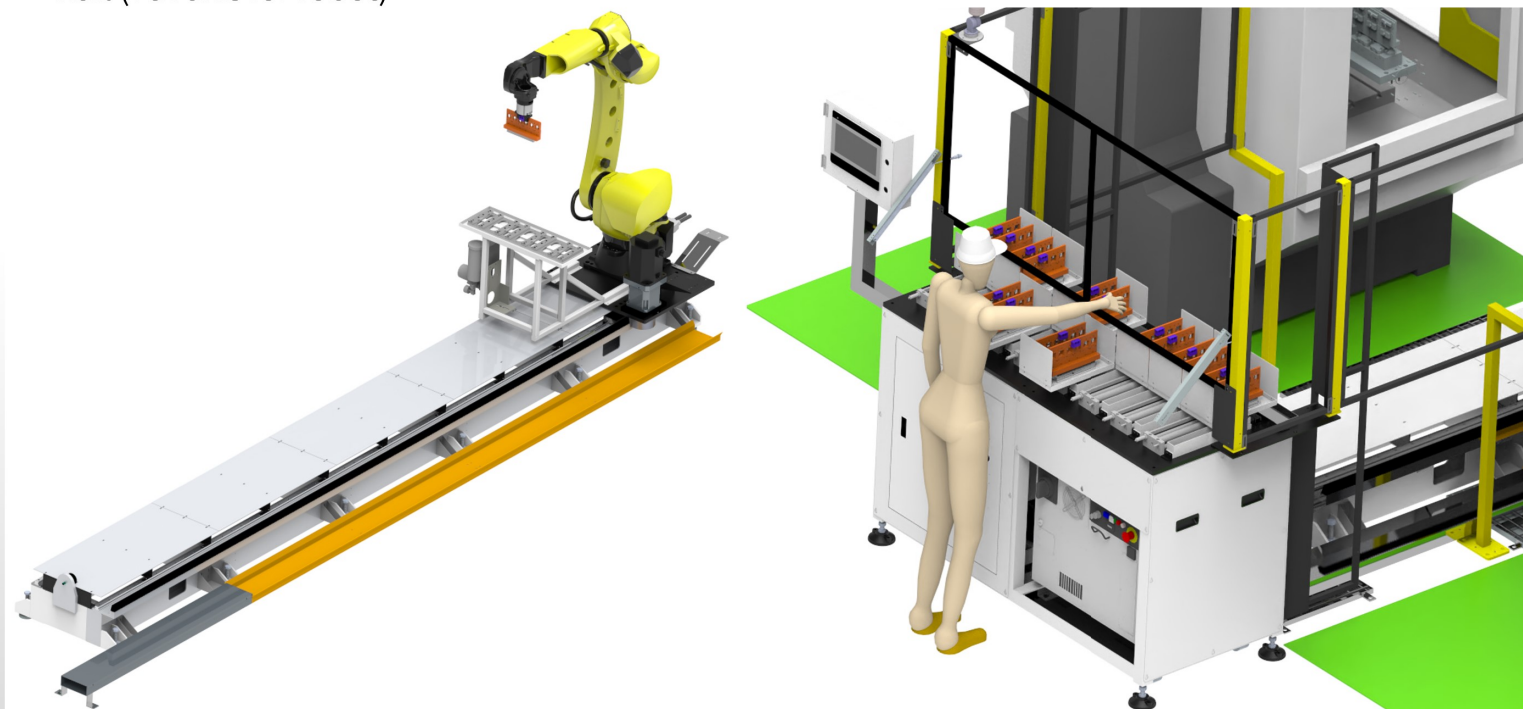

※以上圖片僅供參考，請以實際出貨設備/設計為準。
All Pictures shown are for illustration purpose only. Actual product/design may vary due to product enhancement.

關節型機械手臂運用

運用範例:
Example:

關節型機械手臂應用:1對2加工機取放料
Industrial robot application: one robot for CNC load / unload

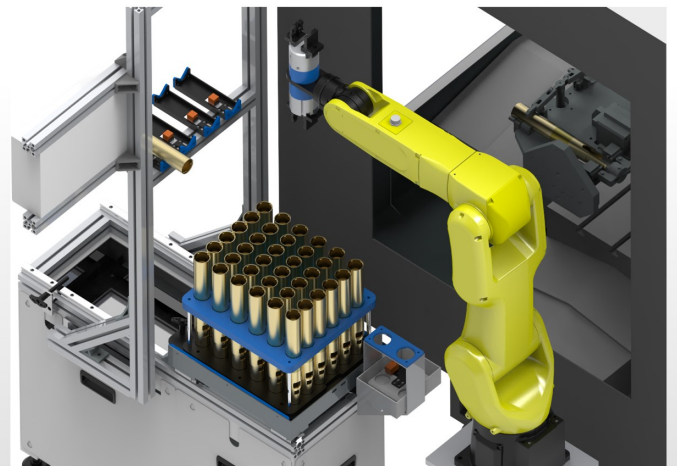
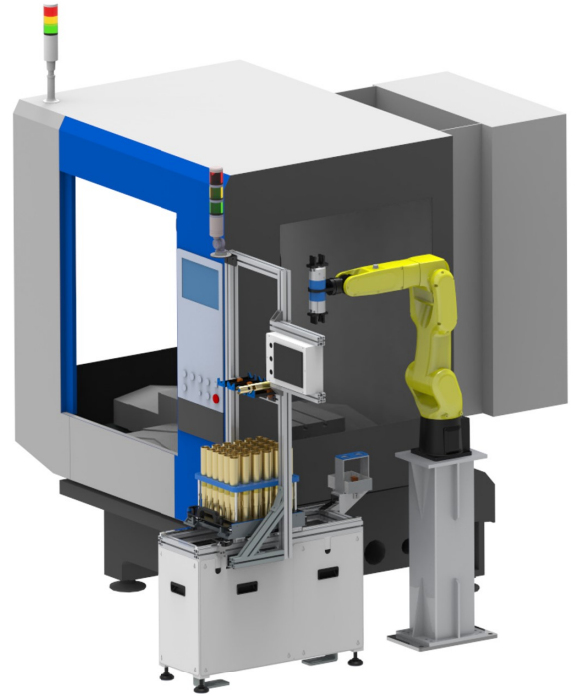

※以上圖片僅供參考，請以實際出貨設備/設計為準。

All Pictures shown are for illustration purpose only. Actual product/design may vary due to product enhancement.

關節型機械手臂運用

運用範例:
Example:

手工具加工產線自動化應用
Hand tool production line automation

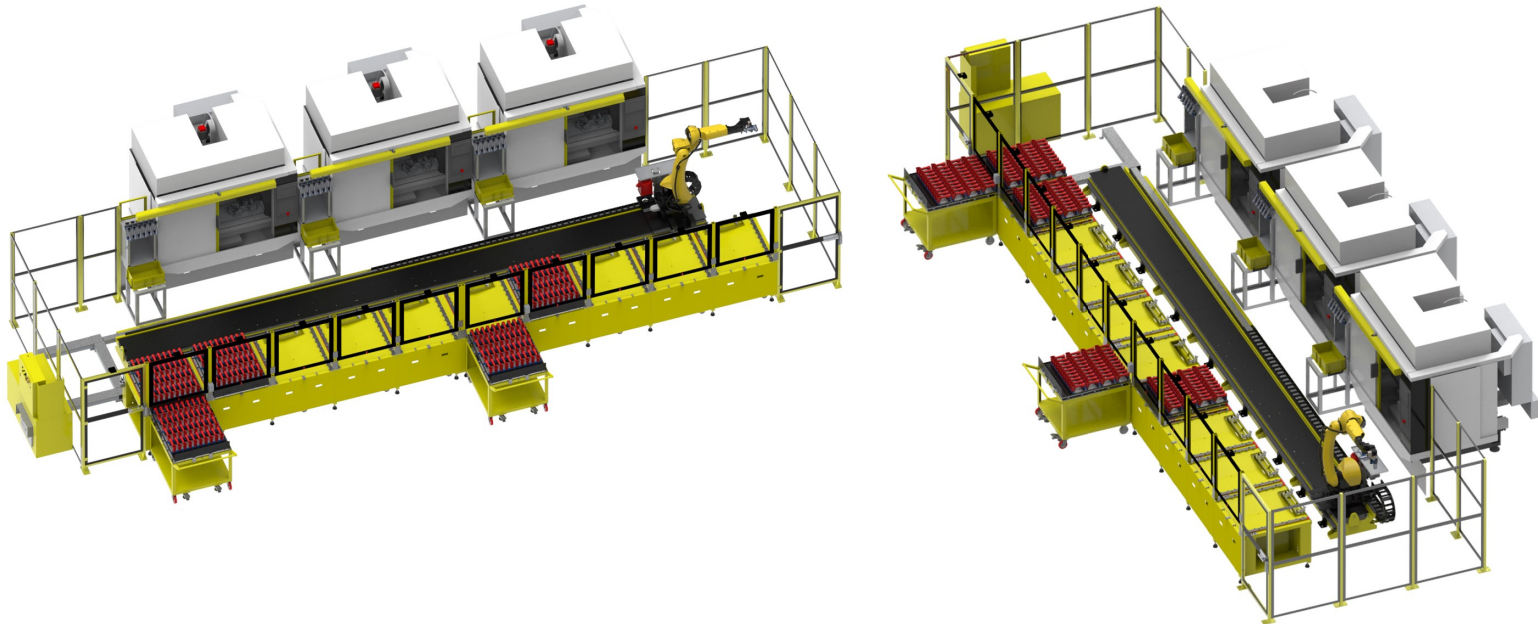

機械手臂自走軸
Industrial robot rail

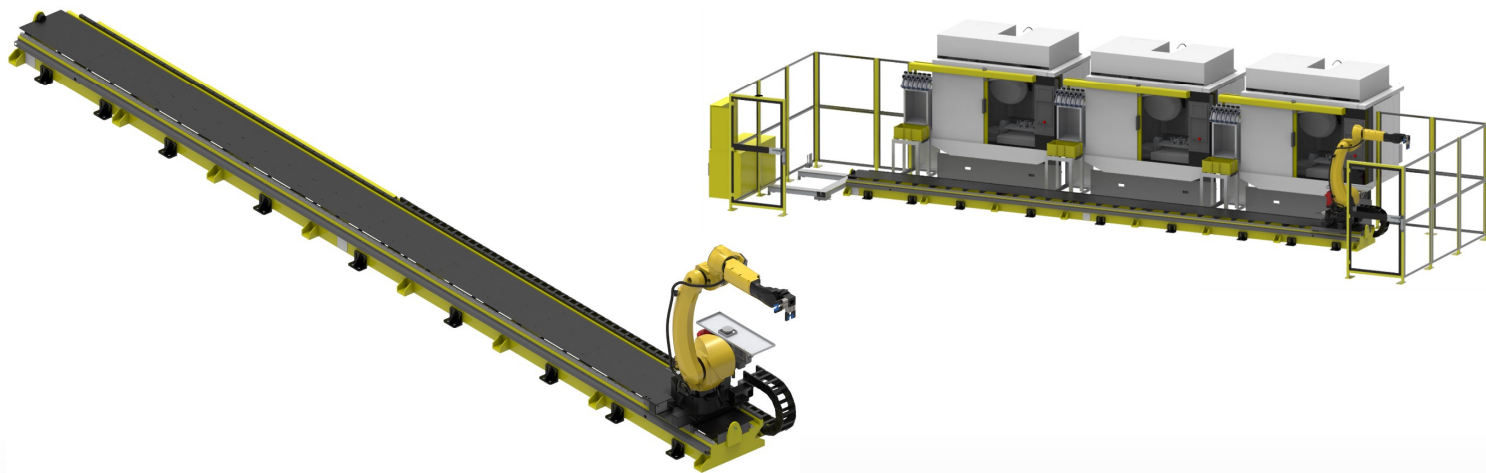

夾爪組
Gripper

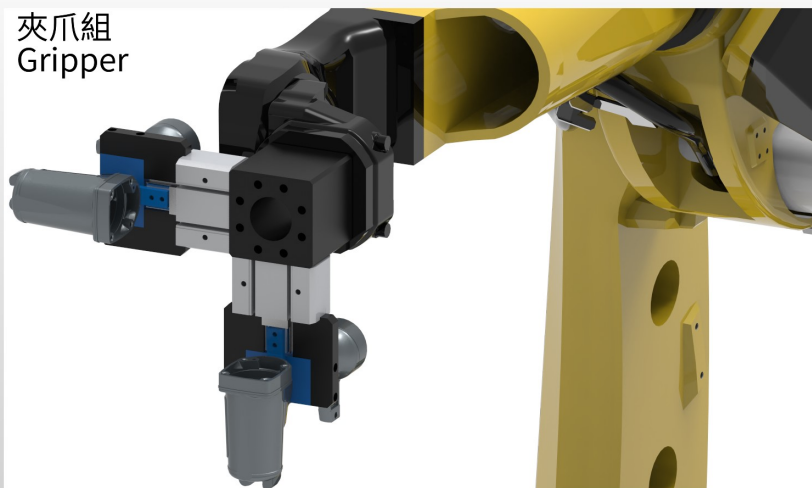

※以上圖片僅供參考，請以實際出貨設備/設計為準。

All Pictures shown are for illustration purpose only. Actual product/design may vary due to product enhancement.